

NOTES:

- MATERIAL:
Housing: HIGH TEMPERATURE THERMOPLASTIC, UL 94V-0, Black.
CONTACT: PHOSPHOR BRONZE, T=0.25mm.
SOLDER TAB: BRASS, T=0.30mm.
Cap: HIGH TEMPERATURE THERMOPLASTIC, UL 94V-0, Black.
- FINISH:
CONTACT: SELECTIVE GOLD PLATING IN THE CONTACT AREA AND SELECTIVE TIN PLATING IN THE SOLDER TAIL AREA, WITH NICKEL UNDER PLATING OVERALL.
METAL CLIP: TIN PLATING WITH NICKEL PLATING OVERALL.
- ELECTRICAL SPECIFICATION:
RATED CURRENT: 1.5A PER PIN POWER TERMINAL;
CONTACT IMPEDANCE: MAXIMUM 30mΩ (INITIAL STAGE);
OPERATING TEMPERATURE: -40°C ~ +85°C.
- SUPPORT SAS 4.0

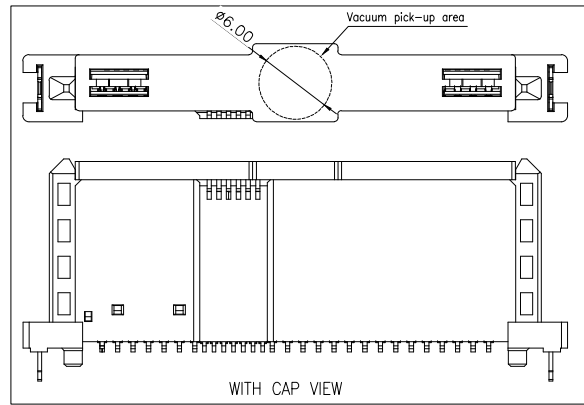
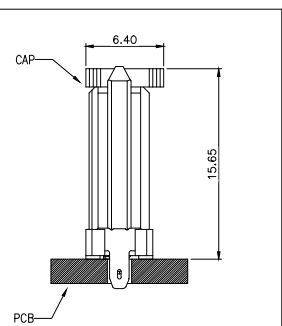
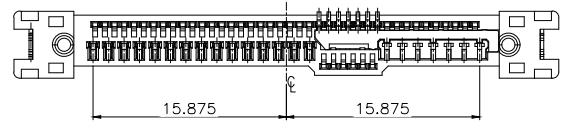
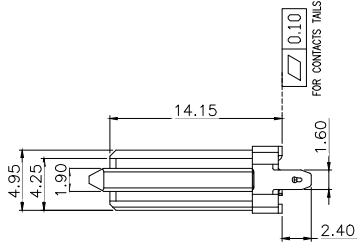
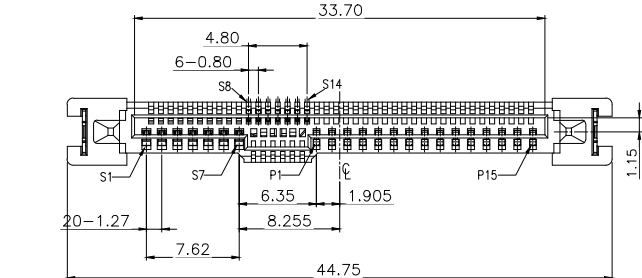

8 08-F V S 02 29 A-30
1 2 3 4 5 6 7 8 9

- HIGH SPEED CONNECTOR
- PITCH: 08: 0.8pitch
- F: FEMALE
- V: 180°
- S: SMT
- 02: TYPE
- PINS NO. 29: 29PINS
- A: LCP BLACK
- Contact Area plating on contacts
- 30: Au 30u"

REV.	REVISION RECORD	DATE	UNIT: MM	GENERAL TOLERANCES		SCALE 1:1	NAME	DATE	PART NO.	DWG NO.	JCTC® TERMINAL&CONNECTORS				
				LINEAR	ANGLES										
A0	新图面发行	22.12.13		0.0±0.30	X° REF±6°	APPROVED	Frey Yang	24.02.23	808-FVS0229A-30	ENDE05					
A1	ADD WITH CAP VIEW	23.12.04		0.00±0.25	X° ±3°	DESIGNER	Daniel Dong	24.02.23							
A2	ADD DIMENSION	24.02.23		0.000±0.10	X° X° ±2°	DRAWN	Jackie Tan	24.02.23	TITLE			REV	A2	SHEET	1/1

环保物料

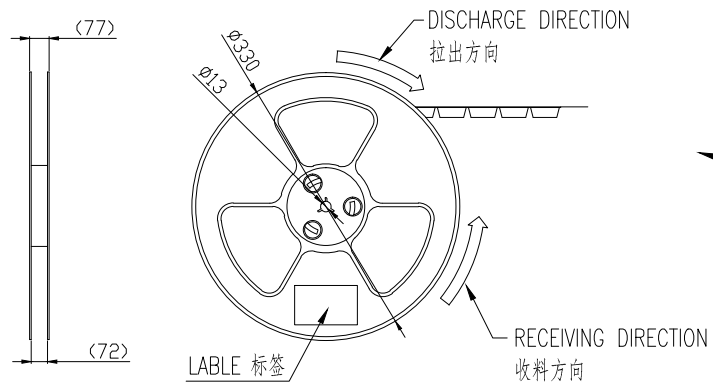
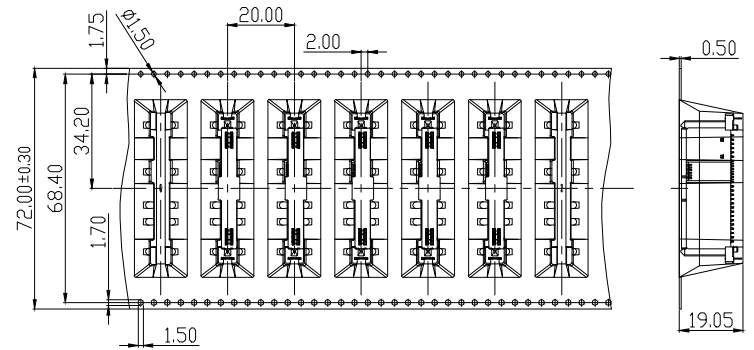
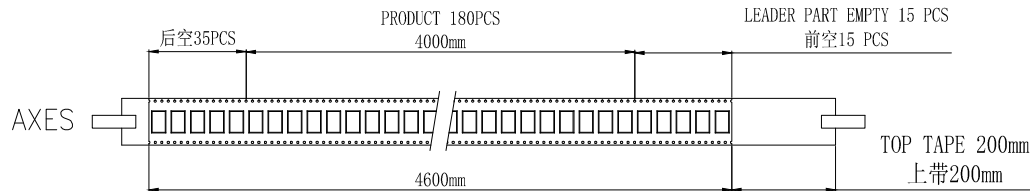

COVER TAPE PEEL STRENGTH: 20~120g
上带剥离力量: 20~120g
速度 PEEL SPEED: 300mm/minute

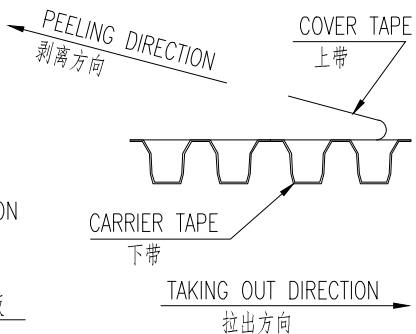

REEL/PCS	CARTON/R	CARTON/PCS
180	3	540

SINGLE HOLE: NONE HOLE SIDE
单孔: 贴无链孔侧
DOUBLE HOLE: ELLIPTICAL HOLE SIDE
双孔: 贴椭圆孔侧

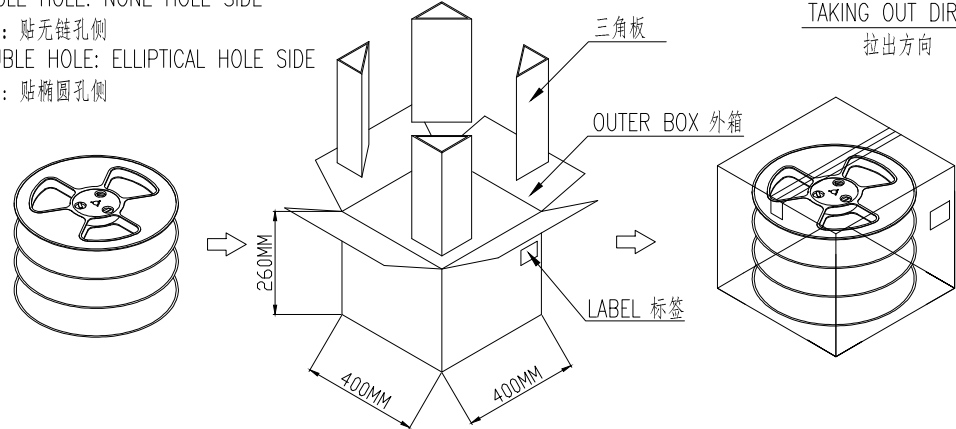

- NOTE:
- CARRIER CAMBER IS WITHIN 1MM IN 100mm ;
带长100mm内容许弯曲度1mm;
 - 10 SPROCKET HOLE PITCH CUMULATIVE TOLERANCE±0.2mm;
圆孔十个孔距离累计允许公差为±0.2mm
 - CARRIER TAPE MATERIAL FOR PS ;
下带材质为PS材质; COLOR颜色: BLACK黑色;
 - BRACER保护带: COLOR颜色: NATURAL透明色; 厚度0.40mm最小;
 - THICKNESS=0.50±0.05 ; 材料厚度为0.50±0.05mm;
 - COVER TAPE上带: 冷风自粘带;

REV.	REVISION RECORD	DATE	GENERAL TOLERANCES	SCALE 1:1	NAME	DATE	PART NO.	DWG NO.	JCTC® TERMINAL&CONNECTORS			
A0	新图面发行	22.12.15	0.0±0.30	X° REF±6°	Daniel Dong	24.08.28	808-FVS0229A-30	ENDE05	SAS V/T 29PIN FEMALE			
A1	修改包装规格及数量	24.04.12	0.00±0.25	X° ±3°	Jackie Tan	24.08.28	TITLE					
A2	修改包装方式及数量	24.08.28	0.000±0.10	X° X° ±2°	Jackie Tan	24.08.28						