

SPECIFICATIONS :

Voltage Rating: 600V AC / DC  
 Current Rating: 9A  
 Withstanding Voltage: 1500V AC/minute  
 Temperature Range:  $-40^{\circ}\text{C} \sim +105^{\circ}\text{C}$   
 Insulation Resistance: 1000M $\Omega$  Min.  
 Contact Resistance: 20m $\Omega$  Max.  
 After environmental testing: 40m $\Omega$  Max.

Material:

Wafer: PA9T HF UL94V-0,  
 Color:Natural/Black  
 Conductor: C2680.  
 Tin-Plated 100u"Min.& 50u"Min.  
 Ni Plated Base  
 Solder Resistance:265 $\pm 5^{\circ}\text{C}$   
 Insertion Force:1.0Kg/f MAX/PIN  
 Withdrwal Force:0.2Kg/f MIN/PIN

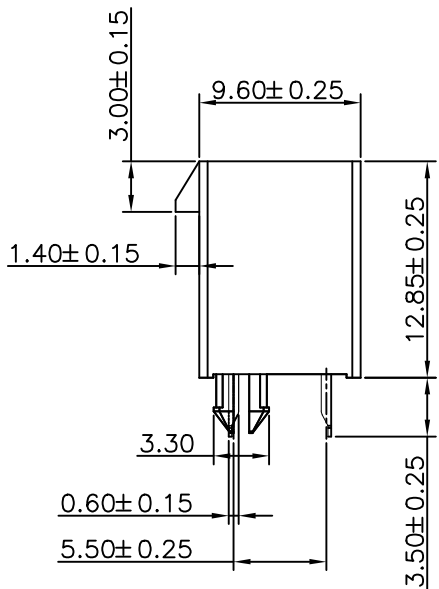
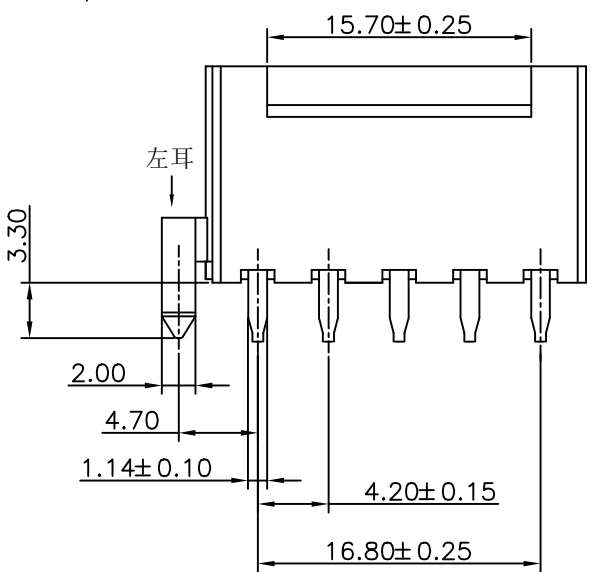

34202W09-2x5Px-LHD

Series No. | 180度 特殊框口 挂台加长 | 无卤+无MYLAR+载带包装

双排针 | 单排Pin数 | 带左耳

空: PA9T 本色  
 A: PA9T 黑色

REV.	REVISION RECORD	DATE	GENERAL TOLERANCES		SCALE	NAME	DATE	PART NO.	DWG NO.		
AO	新版发行	24.09.06	LINEAR	ANGLES	1:1	董东平	24.09.06	34202W09-2x5Px-LHD	ENDE05		
			0.0±0.25	X° REF±6°	APPROVED	马 仟	24.09.06	TITLE			
			0.00±0.15	X° ±3°	DESIGNER	张 硼	24.09.06	4.20mm PITCH DIP TYPE 180° WAFER 特殊框口			
			UNIT: MM		DRAWN			REV	AO	SHEET	1/1

# 包装规范

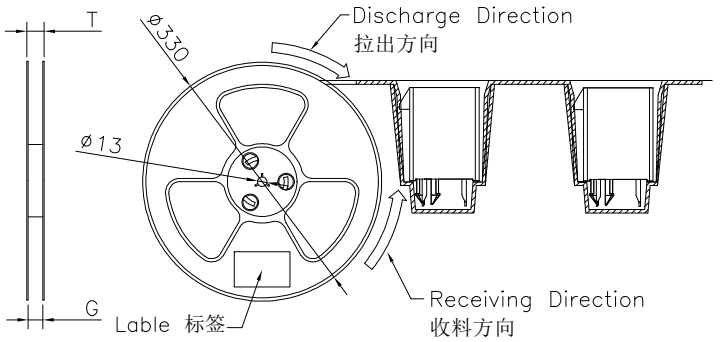
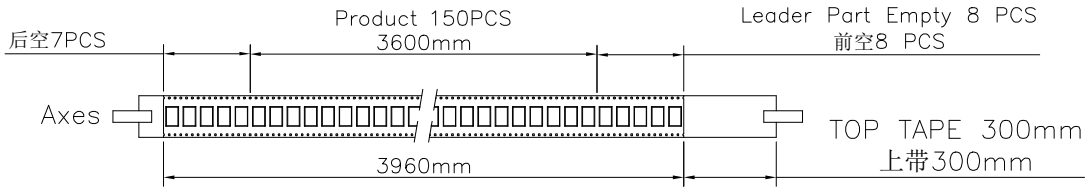

Lable 标签  
 Single hole: None Hole Side  
 单孔: 贴无链孔侧  
 Double hole: Elliptical Hole Side  
 双孔: 贴椭圆孔侧

COVER TAPE PEEL STRENGTH: 20~120g  
 上带剥离力量: 20~120g  
 速度 PEEL SPEED: 300mm/minute

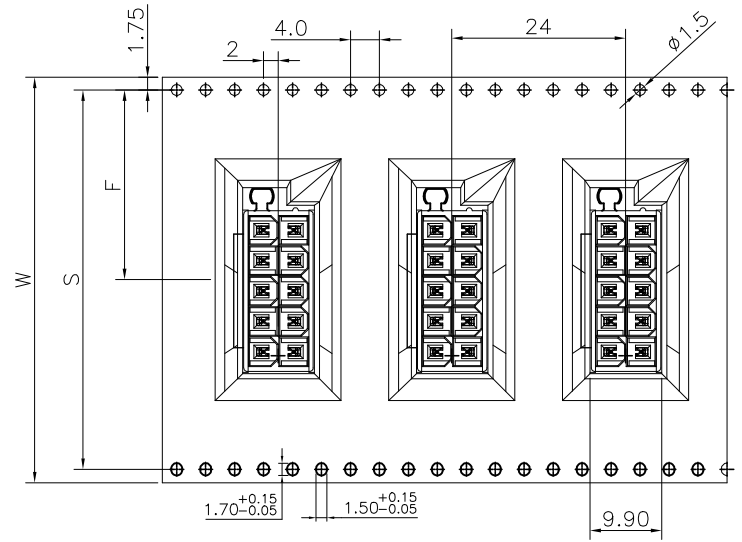
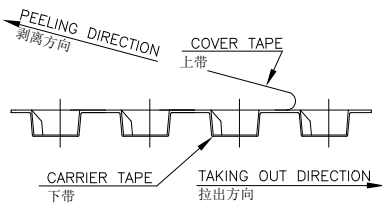

PULLOUT DIRECTION

成品拉出方向

2X2P~2X12P  
 32mm~72mm

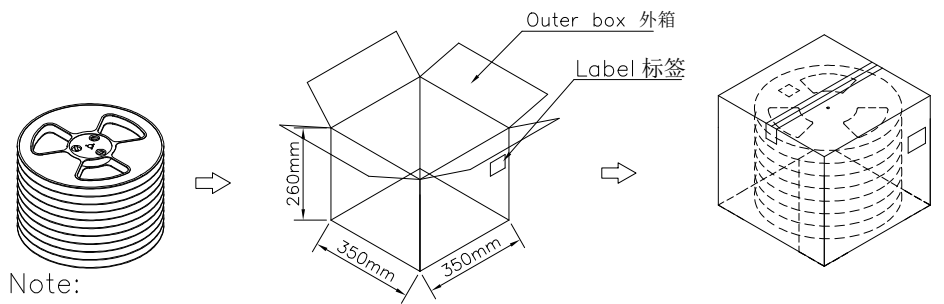

- Note:
- Carrier Camber Is Within 1mm In 100mm ; 带长100mm内容许弯曲度1mm
  - 10 Sprocket Hole Pitch Cumulative Tolerance±0.2MM ; 圆孔十个孔距离累计允许公差为±0.2mm
  - Carrier Tape Material for PS ; 下带材质为PS材质; Color颜色: Black黑色
  - brocer保护带: Color颜色:Natural透明色;厚度0.40mm最小
  - Thickness=0.50±0.05 ; 材料厚度为0.50±0.05mm
  - Cover Tape上带: 冷风自粘带
  - Reel卷盘: PS材质; Color颜色: Blue蓝色

Pin No.	W	S	F	T	G	Cover Tape(宽度) 上带(W)	Carrier Tape(Color) 下带(颜色)	REEL /PCS	CARTON /R	CARTON /PCS
2X5P	56	52.4	26.20	60.5	56.4	49.5	黑色	150	4	600

一般公差 GENERAL TOLERANCE					绘图 DR.	张 硼	料号 PART NO.		文件编号 NUMBER		
X.X	±0.30	X°	±2°	PK-34202W09-2x5PX-LHD			ENDPW10				
X.XX	±0.20	X.X°	±1°	品名TITLE		4.2mm Crimp Style connectors					
A0	24.09.08	新图面发行	马 仟	董东平	核准 APPD.		比例SCALE 1:1		SHEET 1/1	版次 REV. AO	
版次 REV.	日期 DATE	变更内容 DESCRIPTION	审核CHK.	核准APPD.	单位 UNIT mm						