

环保物料

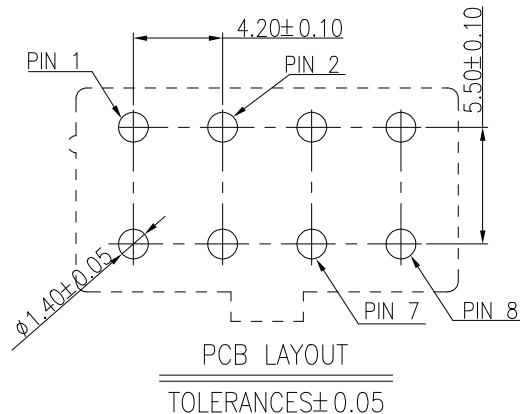

SPECIFICATIONS :

Voltage Rating: 600V AC / DC
 Current Rating: 9A AC / DC
 Withstanding Voltage: 1500V AC/minute
 Temperature Range: -40°C~+105°C
 Insulation Resistance: 1000MΩ Min.
 Contact Resistance: 20mΩ Max.
 After environmental testing: 40mΩ Max.

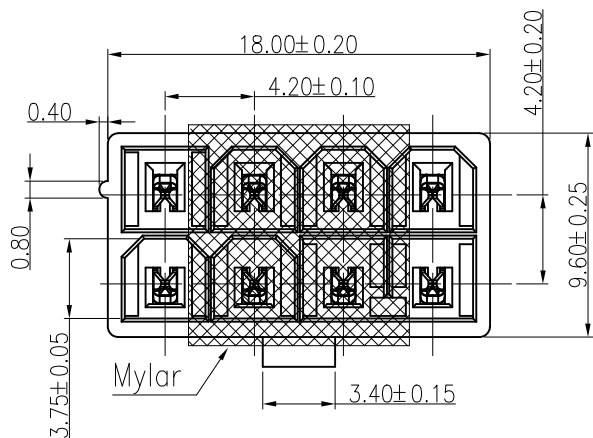

Material:

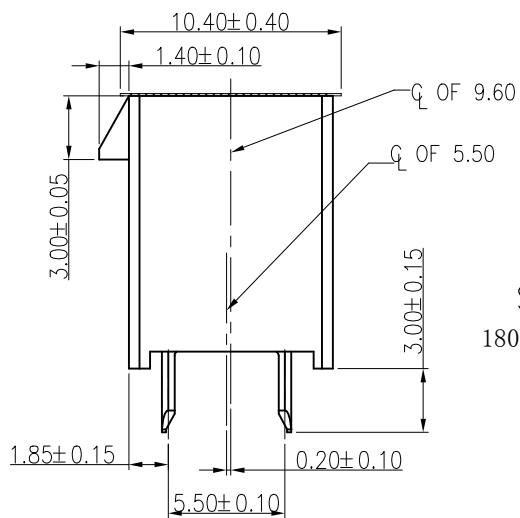
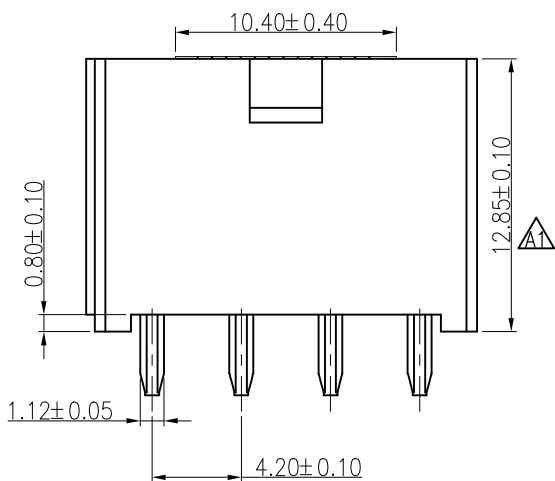
Wafer: LCP HF UL94V-0,
 Color:Black
 Conductor: C18400.
 Tin-Plated 100u"Min.& 50u"Min
 Ni Plated Base



34202W08-2xNPX-X X HM

Series No. 180度 特殊框口 中心偏移款
 双排针
 单排Pin数
 B: LCP 黑色
 无卤 贴MYLAR
 P: 高导电
 N: 无耳

REV.	REVISION RECORD	DATE	UNIT: MM	GENERAL TOLERANCES		SCALE 1:1	NAME	DATE	PART NO.	DWG NO.	 TERMINAL&CONNECTORS		
A0	新图面发行	22.08.01		LINEAR	ANGLES	APPROVED	Frey Yang	22.08.01	34202W08-2X4PB-NPHM	ENDE05			
A1	更新尺寸 	22.08.30	0.00±0.25	X° REF±6°	DESIGNER	Daniel Dong	22.08.01	TITLE 4.20mm PITCH DIP TYPE 180° WAFER		REV A1 SHEET 1/1			
			0.00±0.10	X° X'±2°	DRAWN	Micky Ma	22.08.01						

环保物料

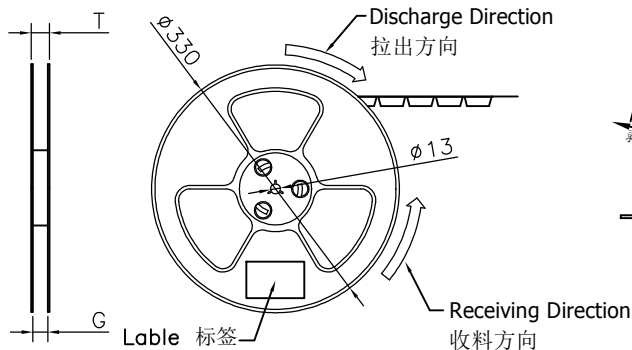
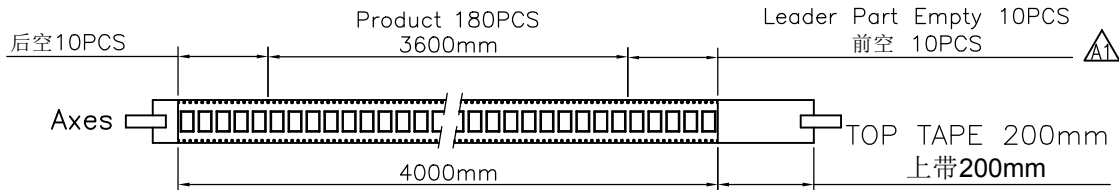

COVER TAPE PEEL STRENGTH:20~120g
上带剥离力量: 20~120g
速度 PEEL SPEED:300mm/minute

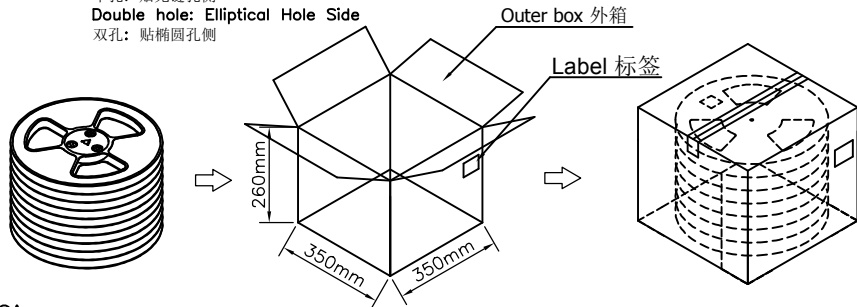
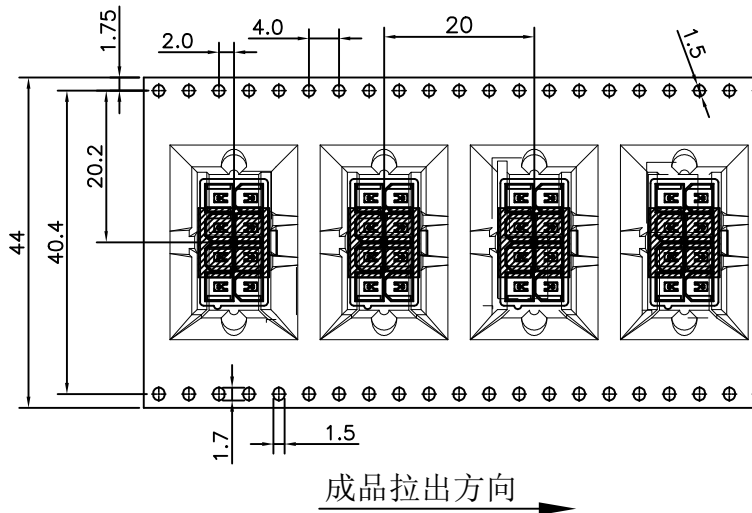
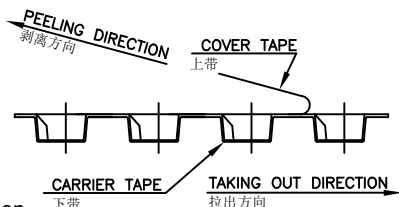

Note:

- Carrier Camber Is Within 1mm In 100mm ; 带长100mm内容许弯曲度1mm
- 10 Sprocket Hole Pitch Cumulative Tolerance ± 0.2 MM ; 圆孔十个孔距离累计允许公差为 ± 0.2 mm
- Carrier Tape Material for PS ; 下带材质为PS材质; Color颜色: Natural透明色
- bracer保护带: Color颜色:Natural透明色;厚度0.40mm最小
- Thickness=0.50 ± 0.05 ; 材料厚度为0.50 ± 0.05 mm
- Cover Tape上带: 冷风自粘带
- Reel卷盘: PS材质; Color颜色: Blue蓝色

Pin No.	W	S	F	T	G	Cover Tape(宽度) 上带(W)	Carrier Tape(Color) 下带(颜色)	REEL /PCS	CARTON /R	CARTON /PCS
2X4P	44	40.4	20.2	48.5	44.4	37.5	透明	180	5	900

REV.	REVISION RECORD	DATE	GENERAL TOLERANCES		SCALE	NAME	DATE	PART NO.	DWG NO.	 JCTC [®] TERMINAL&CONNECTORS			
A0	新图面发行	22.08.01	 LINEAR 0.0 ± 0.30	ANGLES X° REF $\pm 6^\circ$	1:1	Frey Yang	22.08.30	34202W08-2X4PB-NPHM	ENDE05				
A1	更新空格数量	22.08.30			APPROVED	Daniel Dong	22.08.30	TITLE	4.20mm PITCH DIP TYPE 180° WAFER				
			UNIT: MM	0.00 ± 0.25	X° $\pm 3^\circ$	DESIGNER	Micky Ma	22.08.30	REV				
			SIZE: A4	0.000 ± 0.10	X° X' $\pm 2^\circ$	DRAWN							