

环保物料

SPECIFICATIONS :

Voltage Rating: 600V AC / DC
 Current Rating: SEE NOTES
 Withstanding Voltage: 1500V AC/minute
 Temperature Range: -40°C~+105°C
 Insulation Resistance: 1000MΩ Min.
 Contact Resistance: 20mΩ Max.
 After environmental testing: 40mΩ Max.

Material:

Wafer: SEE NOTES, HF UL94V-0
 Color:SEE NOTES
 Conductor: SEE NOTES.
 Tin-Plated 100u"Min.& 50u"Min.
 Ni Plated Base
 Solder Resistance:265±5°C
 Insertion Force:1.0Kg/f MAX/PIN
 Withdrwal Force:0.2Kg/f MIN/PIN

框口规格视图

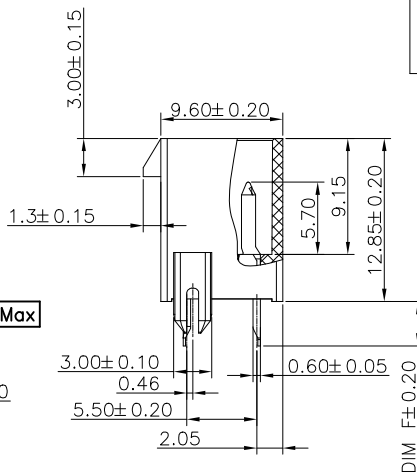
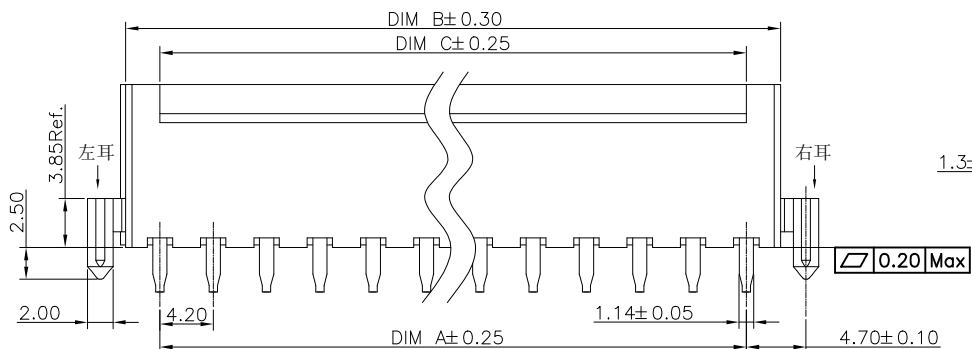
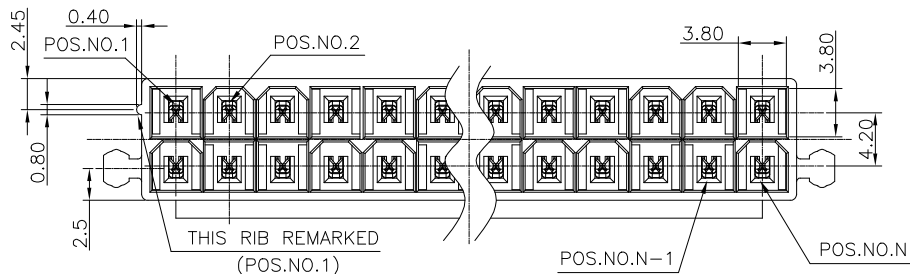
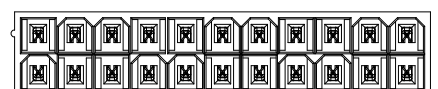
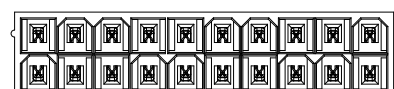
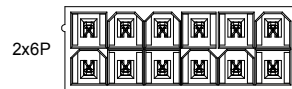
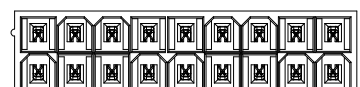
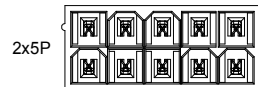
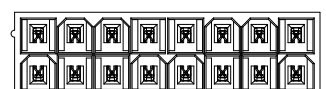
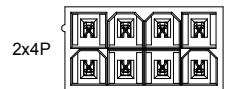
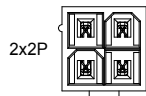

Ordering Information Dimensions

PIN NO.	Dimensions				
	A	B	C	D	E
2x2P	4.20	9.60	3.40	10.4	10.4
2x3P	8.40	13.80	3.40	10.4	10.4
2x4P	12.60	18.00	3.40	10.4	10.4
2x5P	16.80	22.20	3.40	10.4	10.4
2x6P	21.00	26.40	3.40	10.4	10.4
2x7P	25.20	30.60	3.40	26.0	10.0
2x8P	29.40	34.80	3.40	26.0	10.0
2x9P	33.60	39.00	3.40	26.0	10.0
2x10P	37.80	43.20	3.40	26.0	10.0
2x10P	37.80	43.20	37.80	26.0	10.0
2x11P	42.00	47.40	3.40	26.0	10.0
2x12P	46.20	51.60	3.40	26.0	10.0
2x12P	46.20	51.60	46.20	26.0	10.0

REV.	REVISION RECORD	DATE	GENERAL TOLERANCES		SCALE	NAME	DATE	PART NO.	DWG NO.
A0	新图面发行	22.05.26		LINEAR	1:1	Frey Yang	22.05.26	34202W07-2xNPx-xxxx	ENDE05
				0.0±0.30	ANGLES				
				0.00±0.25	X° REF±6°	Daniel Dong	22.05.26	TITLE	4.20mm PITCH DIP TYPE 180° WAFER
				UNIT: MM					
				0.000±0.10	X° X' ±2°	Micky Ma	22.05.26		
				SIZE: A4					

JCTC[®]
 TERMINAL&CONNECTORS

环保物料

规格视图:

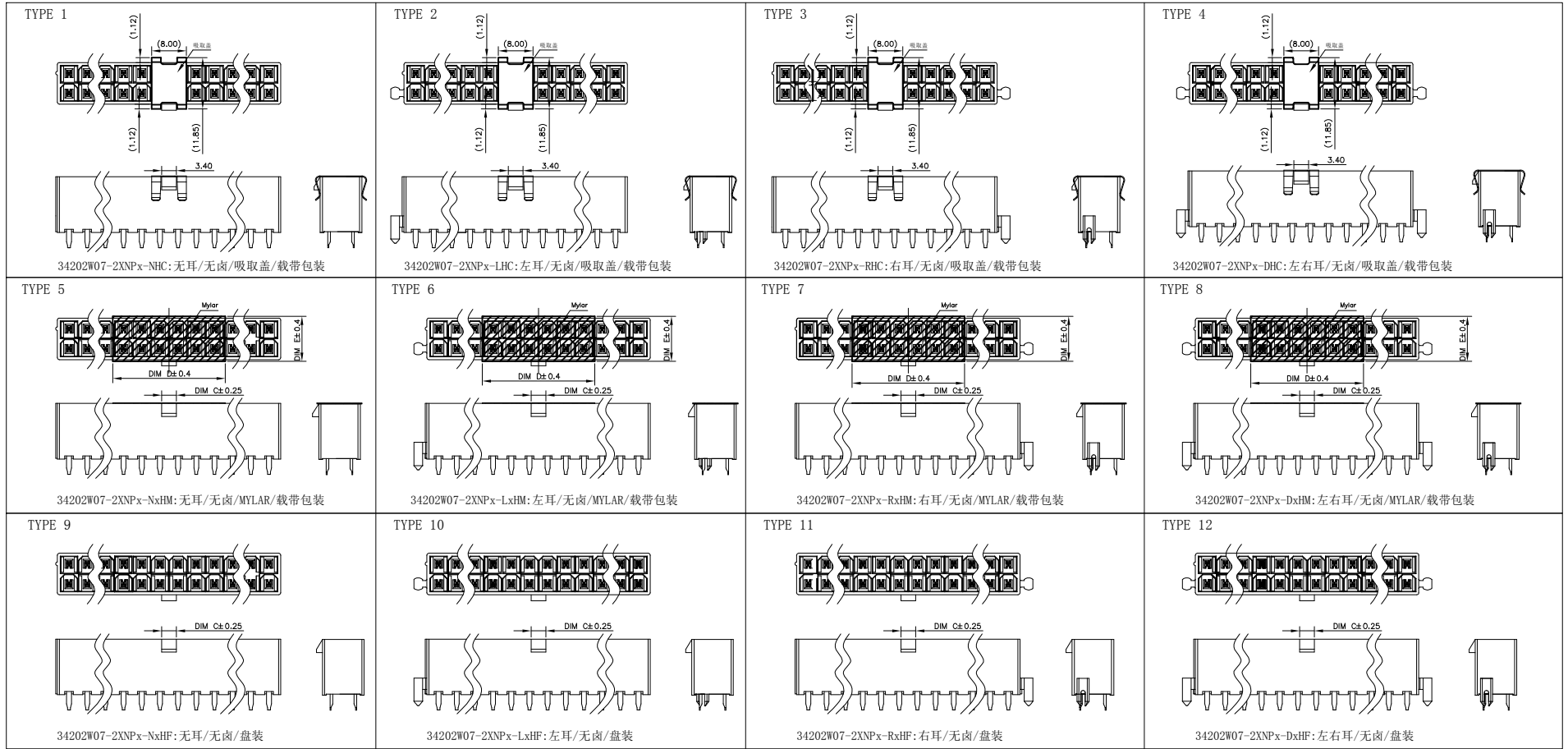

REV.	REVISION RECORD	DATE		GENERAL TOLERANCES		SCALE	NAME	DATE	PART NO.	DWG NO.	 TERMINAL&CONNECTORS	
AO	新图面发行	22.05.26		LINEAR	ANGLES	1:1	Frey Yang	22.05.26		34202W07-2xNPx-xxxx		ENDE05
			0.0±0.30	X° REF±6°	APPROVED	Daniel Dong	22.05.26	TITLE				
			UNIT: MM	0.00±0.25	X° ±3°	DESIGNER	Micky Ma	22.05.26	4.20mm PITCH DIP TYPE 180° WAFER			
			SIZE: A4	0.000±0.10	X° X' ±2°	DRAWN			REV	AO	SHEET	2/4

1

2

3

4

5

6

7

8

环保物料

P.C.B LAYOUT 视图:

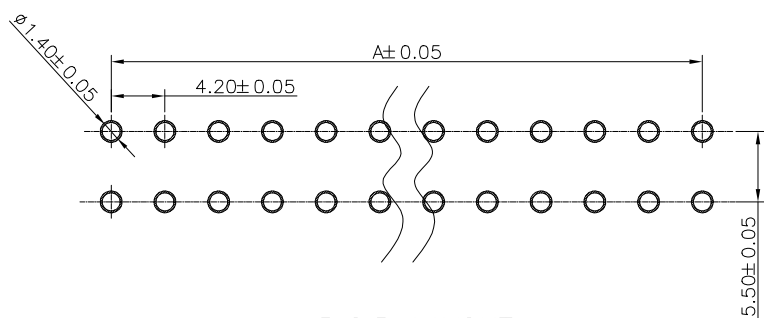

P.C.B LAYOUT
TOLERANCE±0.05

34202W07-2XNPx-Nx-xx: 无耳规格PCB LAYOUT

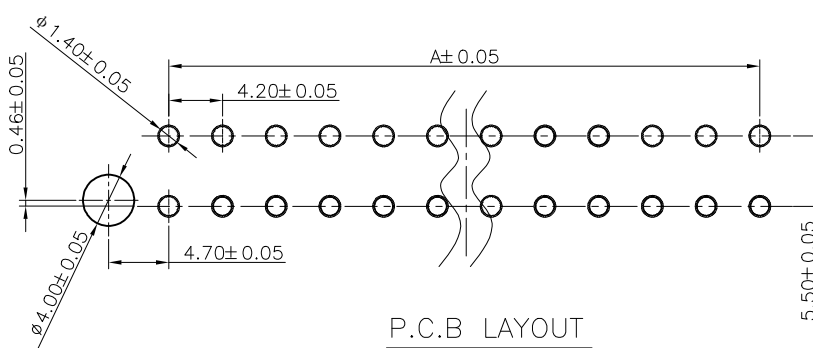

P.C.B LAYOUT
TOLERANCE±0.05

34202W07-2XNPx-Lx-xx: 左耳规格PCB LAYOUT

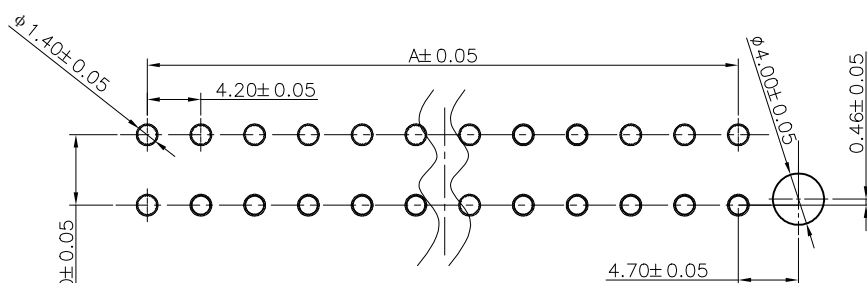

P.C.B LAYOUT
TOLERANCE±0.05

34202W07-2XNPx-Rx-xx: 右耳规格PCB LAYOUT

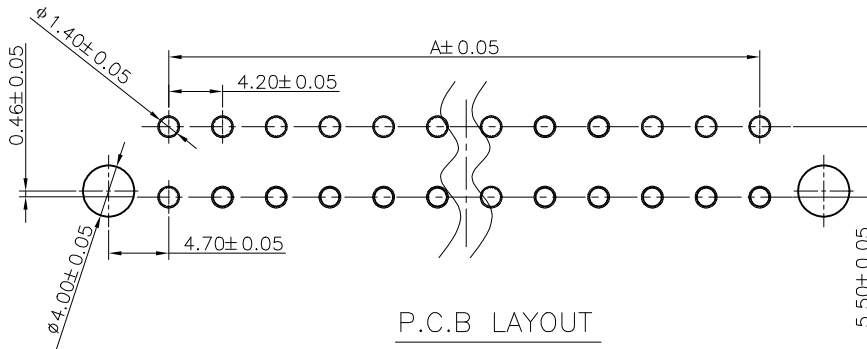

P.C.B LAYOUT
TOLERANCE±0.05

34202W07-2XNPx-Dx-xx: 左右耳规格PCB LAYOUT

REV.	REVISION RECORD	DATE		GENERAL TOLERANCES		SCALE	NAME	DATE	PART NO.	DWG NO.	 TERMINAL&CONNECTORS			
AO	新图面发行	22.05.26		LINEAR	ANGLES	1:1	Frey Yang	22.05.26	34202W07-2xNPx-xxxx	ENDE05				
			UNIT: MM	0.0±0.30	X° REF±6°	APPROVED	Daniel Dong	22.05.26	TITLE		REV	AO	SHEET	3/4
			SIZE: A4	0.00±0.25	X° ±3°	DESIGNER	Micky Ma	22.05.26	4.20mm PITCH DIP TYPE 180° WAFER					
				0.000±0.10	X° X' ±2°	DRAWN								

环保物料

NOTES:

34202W07-2XNPx-xx xx

Series No.

W07:180度 无蘑菇头加筋

2X:双排针

NP:单排Pin数

空: PA9T本色

A: PA9T黑色

W: LCP白色

B: LCP黑色

N: 无耳

L: 带左耳

R: 带右耳

D: 带左右双耳

HF:无卤+盘装 (TYPE 9~12)

HC:无卤+吸取盖+载带包装 (TYPE 1~4)

HM:无卤+MYLAR+载带包装: (TYPE 5~8)

2X7P~2X12P唛拉规格为DIM E(10.0mm) X DIM D(26.0mm)

2X2P~2X6P唛拉规格DIM E(10.4mm) X DIM D(10.4mm)

空: 挂台DIM C尺寸=3.40mm/锡脚DIM F=3.5mm/
端子C2680 (Current Rating:9A)

1: 挂台DIM C尺寸=42.60mm/锡脚DIM F=3.5mm/
端子C2680 (Current Rating:9A)

P: 挂台DIM C尺寸=3.4mm/锡脚DIM F=3.5mm/
端子C1814-H (Current Rating:13A)

2: 挂台DIM C尺寸=37.80mm/锡脚DIM F=3.5mm/
端子C2680 (Current Rating:9A)

REV.	REVISION RECORD	DATE		GENERAL TOLERANCES		SCALE 1:1	NAME	DATE	PART NO.	DWG NO.	 TERMINAL&CONNECTORS			
A0	新图面发行	22.05.26			LINEAR	ANGLES	APPROVED	Frey Yang	22.05.26	34202W07-2xNPx-xxxx				ENDE05
				0.0±0.30	X° REF±6°	DESIGNER	Daniel Dong	22.05.26	TITLE					
			UNIT: MM	0.00±0.25	X° ±3°	DRAWN	Micky Ma	22.05.26	4.20mm PITCH DIP TYPE 180° WAFER		REV	A0	SHEET	4/4
			SIZE: A4	0.000±0.10	X° X' ±2°									

1

2

3

4

5

6

7

8