

环保物料

34202 W00-S 04 C-XX 9 A X R
 ① ② ③ ④ ⑤ ⑥ ⑦ ⑧ ⑨ ⑩

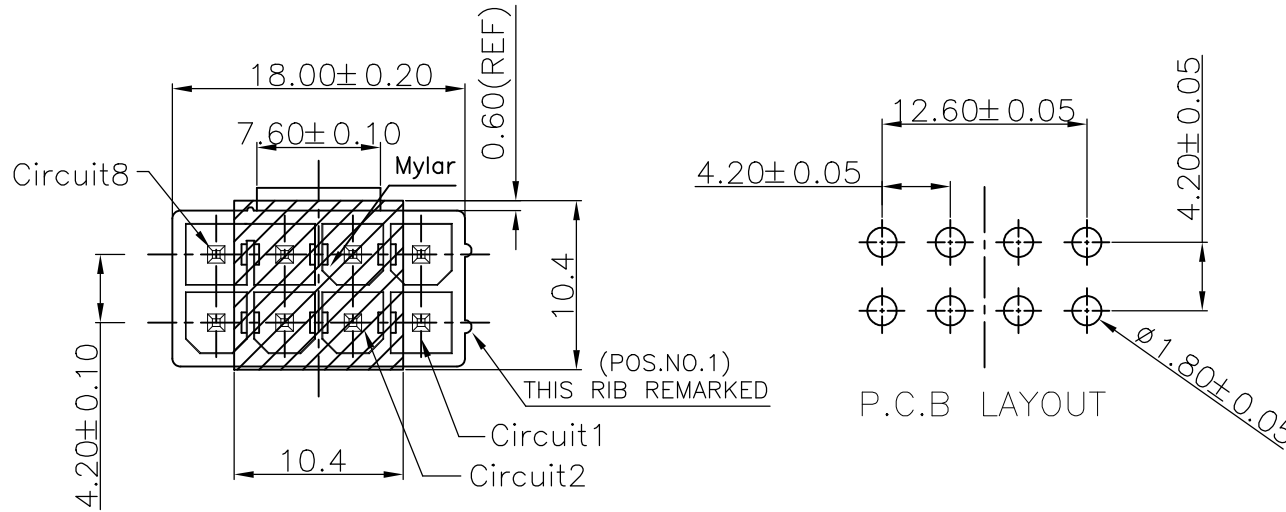

- ① Series No.
- ② W00:180°
- ③ S:双排方针1.07
- ④ XX:单排PIN数04=4PIN
- ⑤ C:第7~8P之间有缺口
- ⑥ 2E=Sn:100u"min Ni:40u"min
3A=Au:3u"min Ni:40u min
- ⑦ Material:
L:LCP 9:PA9T P:Nylon66
- ⑧ Color:
A:Black
- ⑨ Type:
8: DIM A针长=2.50MM
3: DIM A针长=3.50MM
- ⑩ R:载带包装

Specifications :

Voltage rating: 600V AC / DC
 Current rating: 9A AC / DC
 Withstanding voltage: 1500V AC/minute
 Temperature range: -40°C~+105°C
 Insulation resistance:≥1000MΩ
 Contact resistance: ?10mΩ
 After environmental testing: ≤20mΩ
 PIN keeping force:After 3 reflow soldering
 1.5Kgf/Pin Min.
 Salt Spray:48H

Material:

Material: PA9T UL94V-0,HF
 Color: Black
 PIN Material: Brass(C2680),
 2E=Sn:100u"min Ni:40u"min
 3A=Au:3u"min Ni:40u min

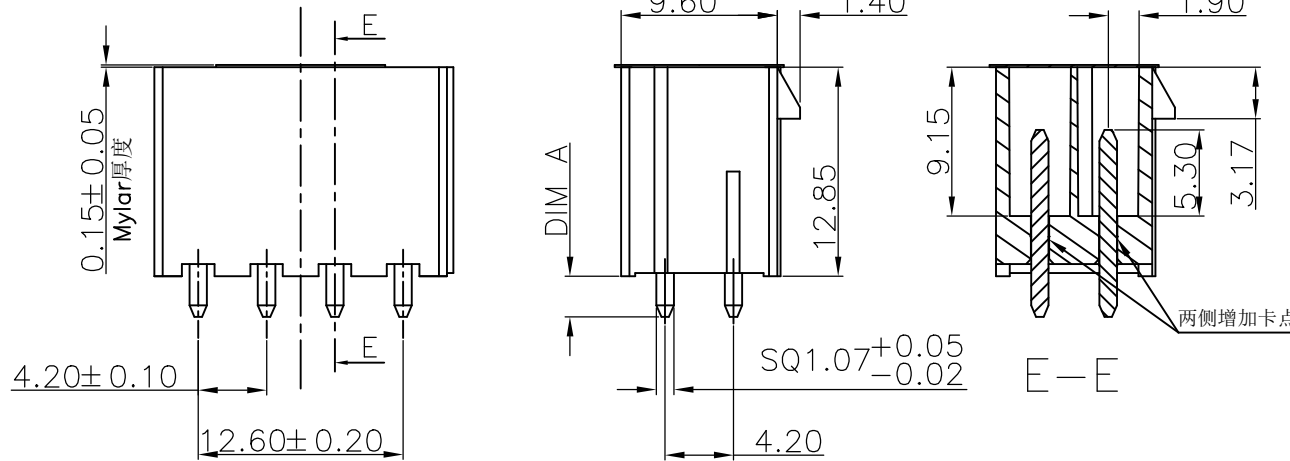

REV.	REVISION RECORD	DATE	GENERAL TOLERANCES		SCALE	NAME	DATE	PART NO.	DWG NO.	 TERMINAL&CONNECTORS			
A0	新图面发行	21.02.26		LINEAR	1:1	Frey Yang	21.09.17	34202W00-S04C-XX9AXR	ENDE05				
A1	增加针长规格	21.09.17		ANGLES	APPROVED	Daniel Dong	21.09.17	TITLE	4.20mm Pitch 180° Dual Row Wafer				
			UNIT: MM	0.00±0.25	X° ±3°	DESIGNER	Micky Ma	21.09.17					
			SIZE: A4	0.000±0.10	X° X' ±2°	DRAWN							

包装规范

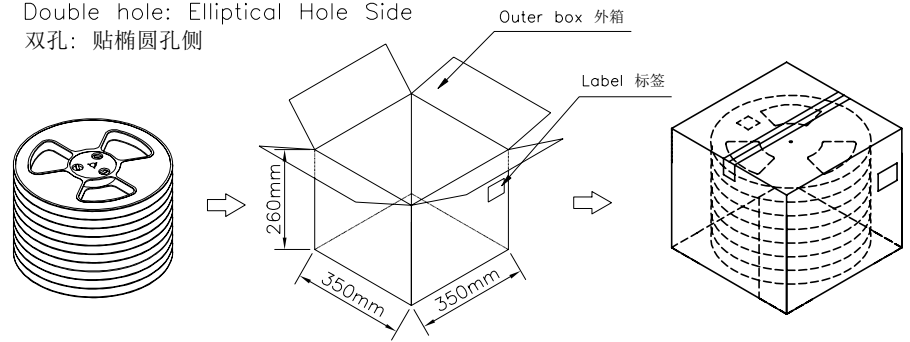
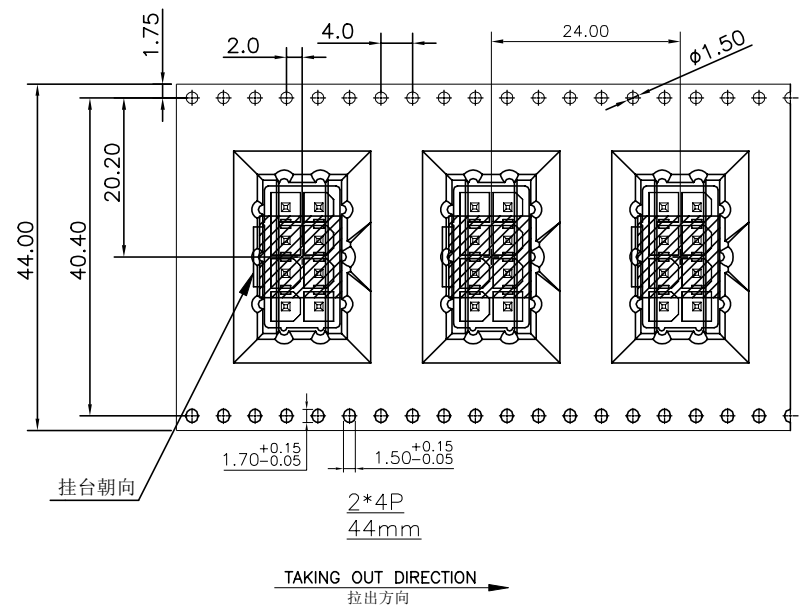
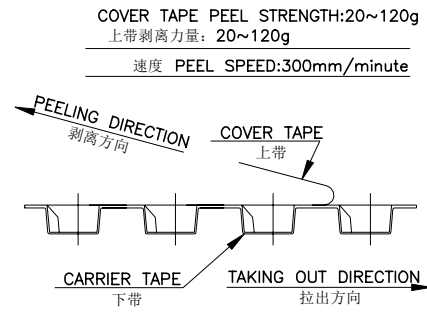
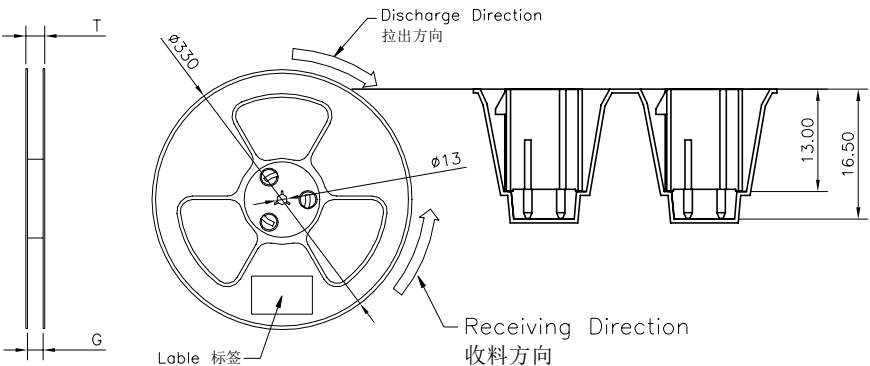
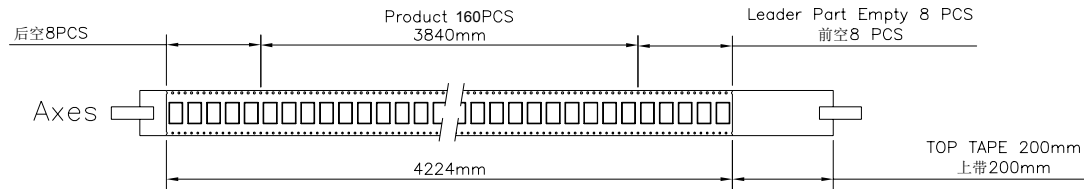

- Note:
- Carrier Camber Is Within 1mm In 100mm ; 带长100mm内容许弯曲度1mm
 - 10 Sprocket Hole Pitch Cumulative Tolerance±0.2MM ; 圆孔十个孔距累计允许公差为±0.2mm
 - Carrier Tape Material for PS ; 下带材质为PS材质; Color颜色: Black黑色
 - bracer保护带: Color颜色:Natural透明色;厚度0.40mm最小
 - Thickness=0.50±0.05 ; 材料厚度为0.50±0.05mm
 - Cover Tape上带: 冷风自粘带

Pin No.	W	S	F	T	G	(宽度) 上带(W)	下带(颜色)	REEL /PCS	CARTON /REEL	CARTON /PCS
2X4P	44	40.40	20.20	48.5	44.4	37.5	黑	160	5	800

					一般公差 GENERAL TOLERANCE		绘图 DR.		料号 PART NO.		文件编号 NUMBER				
					X.X ±0.30	X° ±2°	张 硼		PK-34202W00-S04C-xx9AxR		ENDPW10				
					X.XX ±0.20	X.X° ±1°	审核 CHK.		品名 TITLE				比例 SCALE	SHEET	版次 REV.
A1	24.07.08	文控合并增版发行	马 仟	董东平	X.XXX ±0.10		核准 APPD.		4.2mm Crimp Style connectors				1:1	1/1	A1
A0	21.03.04	新发行	董东平	杨章雄	单位 UNIT		核 准								
版次 REV.	日期 DATE	变更内容 DESCRIPTION	审核 CHK.	核准 APPD.	mm										